

Temperature sensors for heating systems and heat engineering TOP-216

Technical description

Measuring range / sensing element		
(-50 ÷ 200) °C	Pt100, Pt500, Pt1000	class B
Thermowell		
– material: steel 1.4541		
– diameter: d [mm]: ø6 for TOP 216A, d [mm]: ø8 for TOP 216B		
– length L [mm]: 70÷700		
– extension length D [mm]: 50÷200		
– minimum immersion depth [mm]: 70		
Connection head		
– MA, IP54 (-40 ÷ 100) °C		
Options		
– Ni100, Ni1000		
– double measuring circuit (only 2-wire connection connection)		
– other inch and metric threads		
– Pt100: class A (-30 ÷ 200) °C, class AA (0 ÷ 150) °C		
Additional accessories		
– process thermowell OGG for TOP-216A sensor material: steel 1.4541, length L _o =L-20 [mm]		

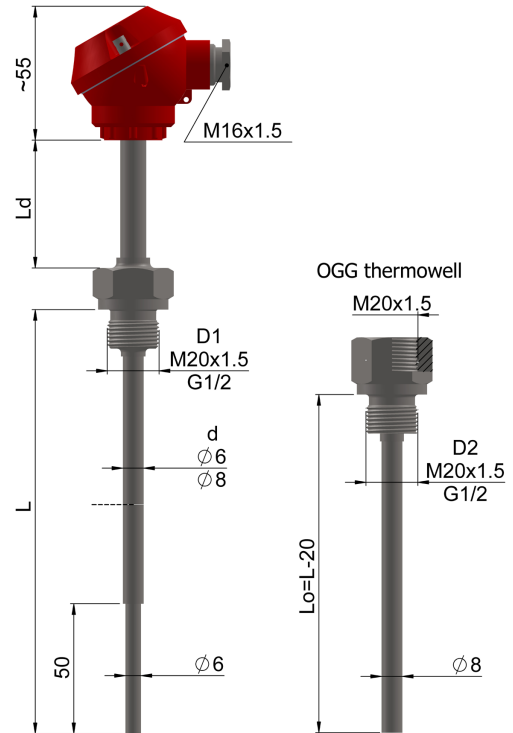

Response time T05/T09

Sensor type	ø9	ø11
Pt	≤33/≤95	≤40/≤120
J, K insulated junction	≤22/≤62	≤a27/≤90
J, K grounded junction	≤3/≤8	≤6/≤15

Resistors tolerance acc. to PN-EN 60751

Class	Wire wound resistor	
	Range [°C]	Tolerance [°C]
AA	(-50÷250)	±(0,1+0,0017· t)
A	(-100÷450)	±(0,15+0,002· t)
B	(-196÷600)	±(0,3+0,005· t)

Ordering code

Temperature sensor	TOP-216	-	...	-	...	-	...	-	...	-	...	-	...	-	...	
Straight sheath ø6																A
Strengthen thermowell ø8/ø6																B
Without extension D=0																no sign
With extension D, length [mm]																50÷200*
Length L [mm] (for sensors without thermowell)																70÷700*
Length L _o [mm] (for sensors with thermowell OGG)																70÷700*
Thread dimension D ₁ (for sensors without thermowell)																M20x1,5; G½*
Thread dimension D ₁ (for sensors with thermowell OGG)																M20x1,5
Resistor type																Pt100*
Resistor class																A, B*
Measuring circuit																2, 3, 4
Additional accessories (for TOP-216A sensor): OGG/Thread D ₂																OGG/M20x1,5*

* or others acc. to requirements

Ordering example

TOP-216-A-50-400-M20x1,5-Pt100-A-4-OGG/G½ sensor with Pt100, class A, 4-wire connection, with thermowell ø6, extension D=50 mm and thread M20x1,5, additional process thermowell OGG with length L_o=400 mm, with threaded fastener G½